

DIM.	TOL.
5mm DOWN	±0.2
5~20mm	±0.3
20~40mm	±0.4
40~60mm	±0.5
60~100mm	±0.8
100mm UP	±1.0

REVISIONS			
REV	DESCRIPTION	DATE	BY

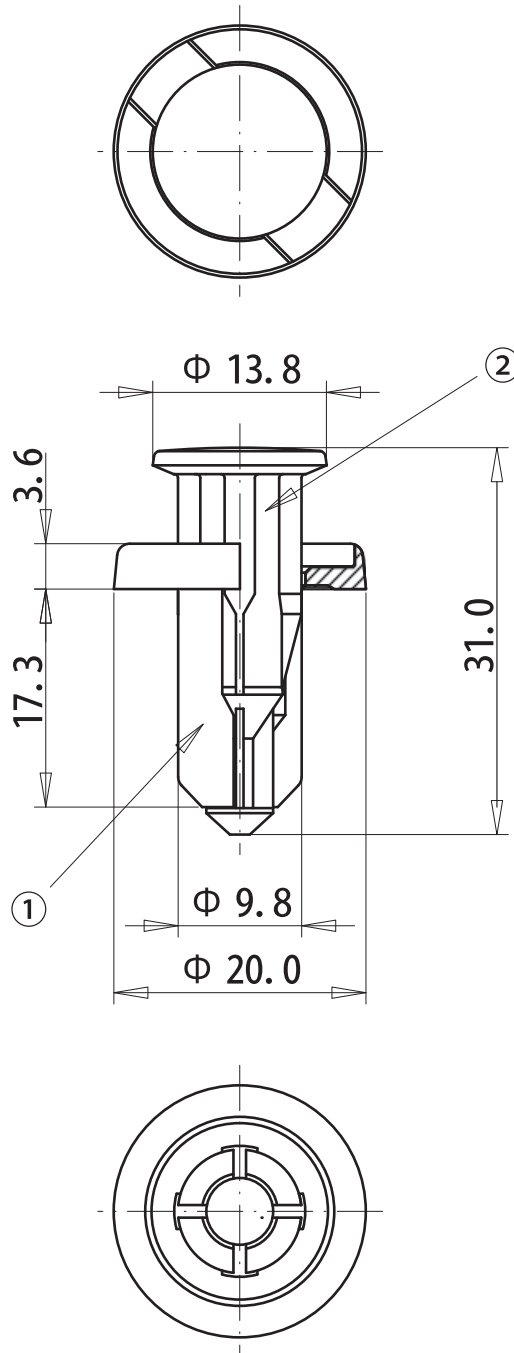

Hole Diam: $\Phi 10.0$
 Panel Thickness: 3.5 - 4.0



				TITLE		TURN RIVET	
				MATERIAL 1		PP	DATE
PART NUMBER		DRAWING NUMBER		MATERIAL 2		DRAWN	
10516GA01		15.09.15.10516.0.E		POM		S.P.	
SIZE		UNIT		COLOR		CHECK	
A4		mm		BLACK			
SCALE		REV		UNLESS OTHERWISE SPECIFIED TOLERANCE		APPROVED	
5:3		A		SEE ABOVE			