

DIM.	TOL
5mm DOWN	±0.2
5~20mm	±0.3
20~40mm	±0.4
40~60mm	±0.5
60~100mm	±0.8
100mm UP	±1.0

REVISIONS			
REV	DESCRIPTION	DATE	BY

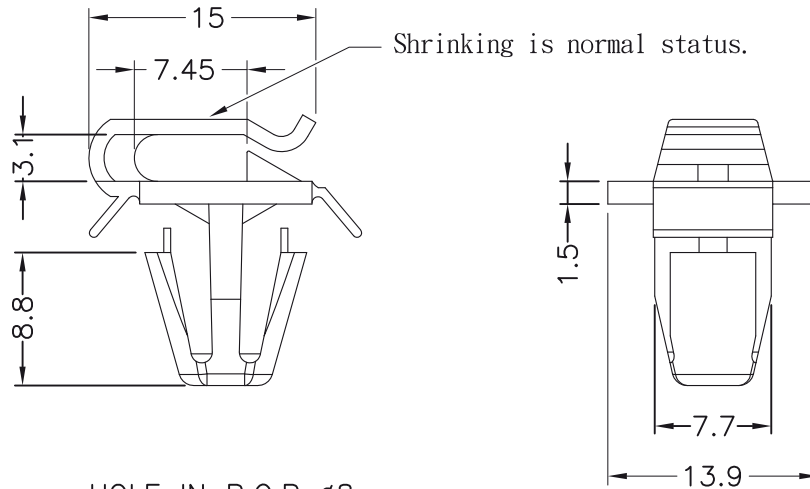

HOLE IN P.C.B $\phi 8$
P.C.B THICKNESS 1.0~2.8

NOTE: All measurement does not include gate which raises under 0.3mm.



fastpoint		TITLE WIRE SADDLE SIDE ENTRY		
		MATERIAL PA66 V2 UL94	DATE 17/05/2011	
		FINISH	DRAWN J.D.	
		COLOR NATURAL	CHECK	
PART NUMBER 10680AA00	DRAWING NUMBER 11.05.17.10680.0.E	UNLESS OTHERWISE SPECIFIED TOLERANCE SEE ABOVE		
SIZE A4	SCALE 2:1	UNIT mm.	REV A	APPROVED