

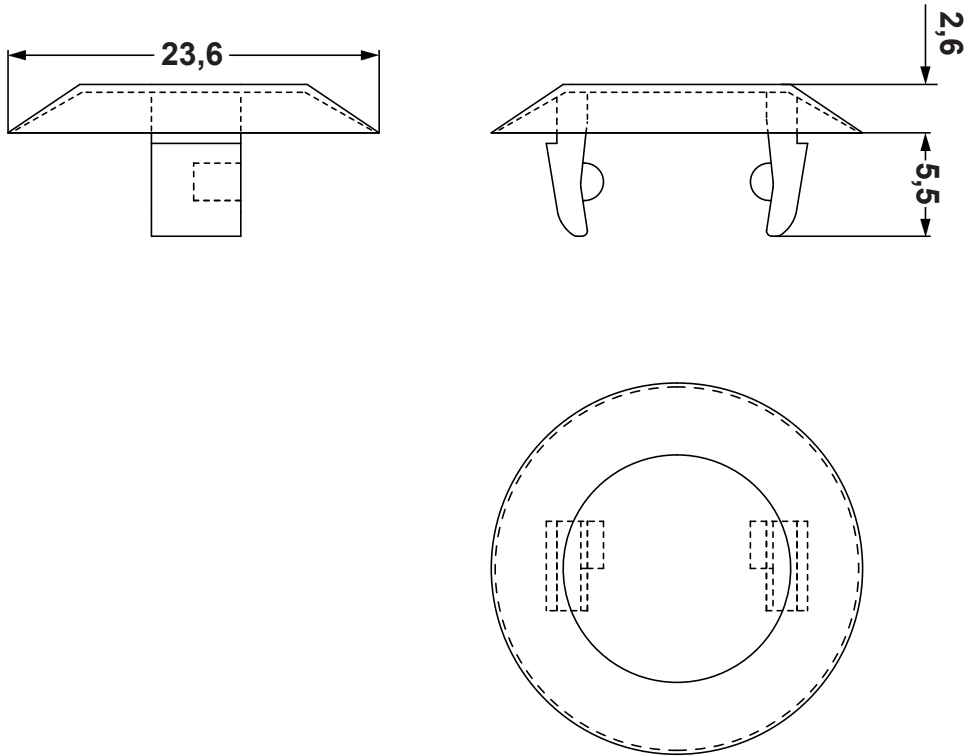

DIM.	TOL.
5mm DOWN	±0.2
5~20mm	±0.3
20~40mm	±0.4
40~60mm	±0.5
60~100mm	±0.8
100mm UP	±1.0

REVISIONS			
REV	DESCRIPTION	DATE	BY



**NOTES: PANEL HOLE: Ø 16,0**  
**PANEL THICKNESS: 0,5 -1,2**

				TITLE <b>PLUGS</b>			
				MATERIAL NYLON 66 UL94V-2		DATE 10/02/2017	
				HARDNESS		DRAWN R.F.	
PART NUMBER 2338AA01		DRAWING NUMBER 17.02.10.2338.0.E		COLOR BLACK		CHECK	
SIZE A4	SCALE NTS	UNIT mm	REV A	UNLESS OTHERWISE SPECIFIED TOLERANCE SEE ABOVE		APPROVED	