

DIM.	TOL.
5mm DOWN	±0.2
5~20mm	±0.3
20~40mm	±0.4
40~60mm	±0.5
60~100mm	±0.8
100mm UP	±1.0

REVISIONS			
REV	DESCRIPTION	DATE	BY

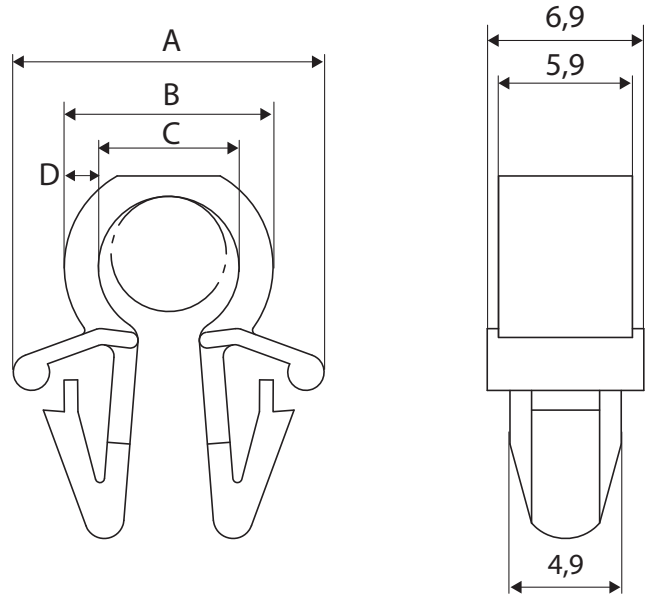

PART N.	A	B	C	D	CLOSED DIAMETER
8081AA00	13,60	9,20	6,30	1,55	5,0
8083AA00	13,20	10,90	8,10	1,50	7,0
8084 AA00	13,40	12,80	9,85	1,35	9,0

MOUNTING HOLE: Ø 6,0 mm
 PANEL THICKNESS: 2,0 mm

NOTE:
 1. Shrinking is normal status.
 2. All measurement does not include gate wich raises under 0.3 mm.

		TITLE		WIRE HOLDER	
		MATERIAL		DATE	
		NYLON 66 UL94V-2		06/10/2015	
PART NUMBER		DRAWING NUMBER		DRAWN	
SEE ABOVE		15.10.06.8081.0.E		S.P.	
SIZE		UNIT		CHECK	
A4		mm		NATURAL	
SCALE		REV		UNLESS OTHERWISE SPECIFIED TOLERANCE	
NTS		A		SEE ABOVE	
				APPROVED	