

DIM.	TOL
5mm DOWN	±0.2
5~20mm	±0.3
20~40mm	±0.4
40~60mm	±0.5
60~100mm	±0.8
100mm UP	±1.0

REVISIONS			
REV	DESCRIPTION	DATE	BY

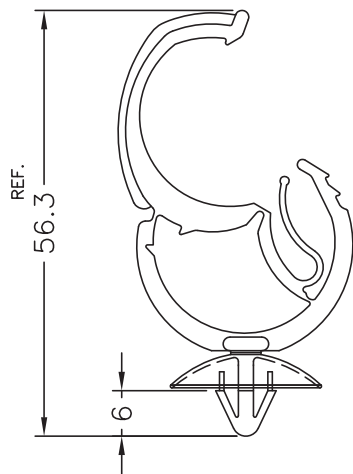

P.C.B $\phi 6.2 \sim 6.7$
THICKNESS 0.5~2.0

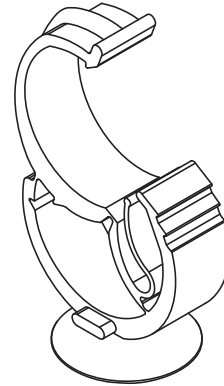
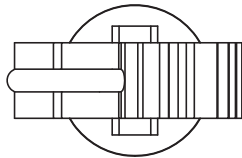
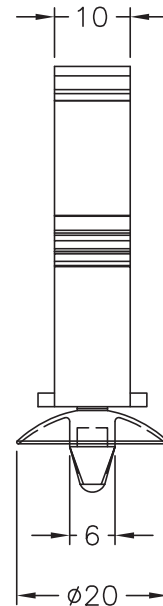

NOTE: Suggest to use wire with diameter $\phi 20$ mm. (MAX)



TITLE WIRE MOUNT	
MATERIAL NYLON 66 UL94V-2	DATE 17/05/2011
COLOR BLACK	DRAWN J.D.
PART NUMBER 8495AA01	DRAWING NUMBER 11.05.17.8495.0.E
SIZE A4	SCALE 1:1
UNIT mm.	REV A
UNLESS OTHERWISE SPECIFIED TOLERANCE SEE ABOVE	CHECK APPROVED