

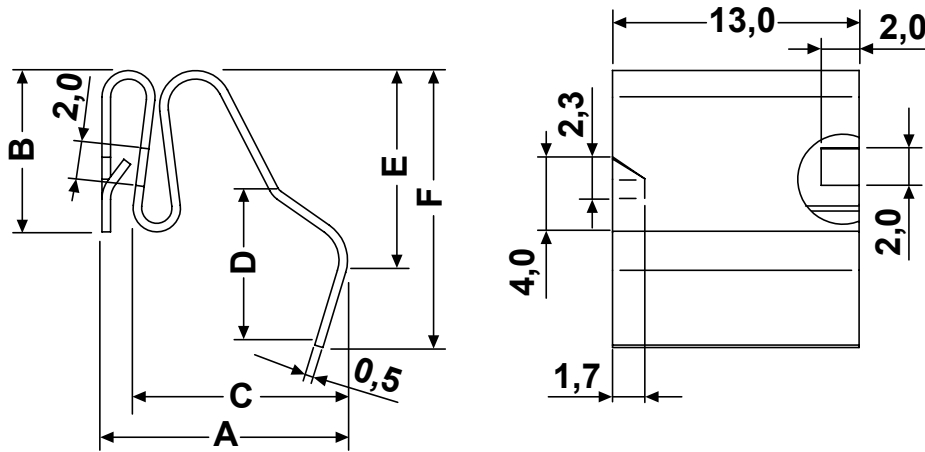

DIM.	TOL.
5mm DOWN	±0.2
5~20mm	±0.3
20~40mm	±0.4
40~60mm	±0.5
60~100mm	±0.8
100mm UP	±1.0

REVISIONS			
REV	DESCRIPTION	DATE	BY



P/N	A	B	C	D	E	F
12000MC92	13,0	8,5	11,3	8,3	10,0	15,5
12001MC92	10,3	13,0	11,5	15,0	23,3	26,0

				TITLE <b>SPRINGS FOR FILTER</b>	
				MATERIAL HARDENED STEEL NICKEL PLATED	
PART NUMBER SEETABLE				DRAWN R.F.	
DRAWING NUMBER 18.01.08.1200X.0.E				CHECK	
SIZE A4	SCALE NTS	UNIT mm.	REV A	UNLESS OTHERWISE SPECIFIED TOLERANCE SEE ABOVE	
				APPROVED	