

DIM.	TOL.
5mm DOWN	±0.2
5~20mm	±0.3
20~40mm	±0.4
40~60mm	±0.5
60~100mm	±0.8
100mm UP	±1.0

REVISIONS			
REV	DESCRIPTION	DATE	BY

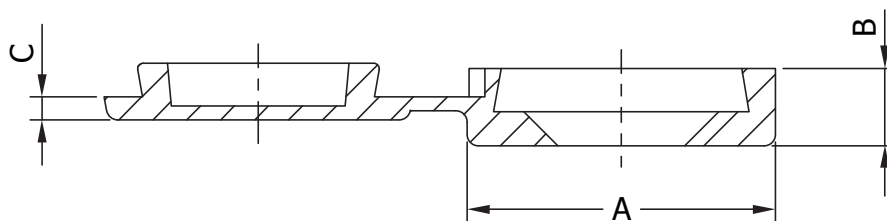

CLOSED

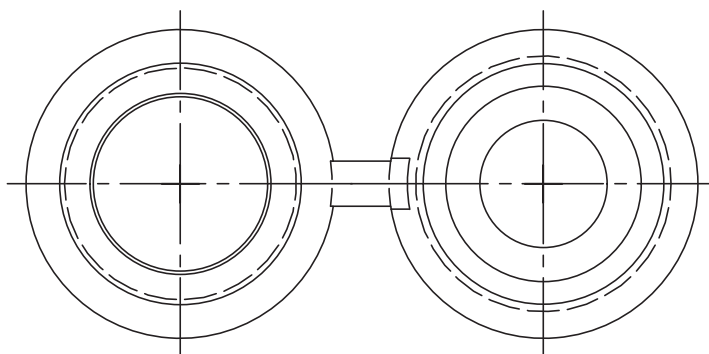
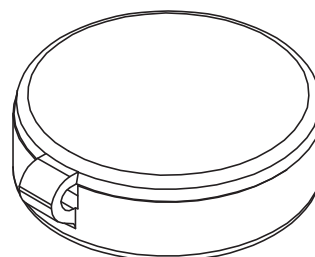

P/N	COLOUR	A	B	C	METRIC SCREW
12350FA02	WHITE	13,6	3,4	1,0	3,5 - 6
12350FA01	BLACK	13,6	3,4	1,0	3,5 - 6
8043FA02	WHITE	17,5	5,0	1,0	5 - 6
8043FA01	BLACK	17,5	5,0	1,0	5 - 6



TITLE
SCREW CAP

MATERIAL
PP POLYPROPYLENE

DATE
31/05/2017

DRAWN
R.F.

COLOR
SEE TABLE

CHECK

UNLESS OTHERWISE SPECIFIED
TOLERANCE
SEE ABOVE

APPROVED

PART NUMBER
SEE TABLE

DRAWING NUMBER
17.05.31.XXXX.0.E

SIZE
A4

SCALE
3:1

UNIT
mm.

REV
A