

DIM.	TOL.
5mm DOWN	±0.2
5~20mm	±0.3
20~40mm	±0.4
40~60mm	±0.5
60 100mm	±0.8
100mm UP	±1.0

REVISIONS			
REV	DESCRIPTION	DATE	BY

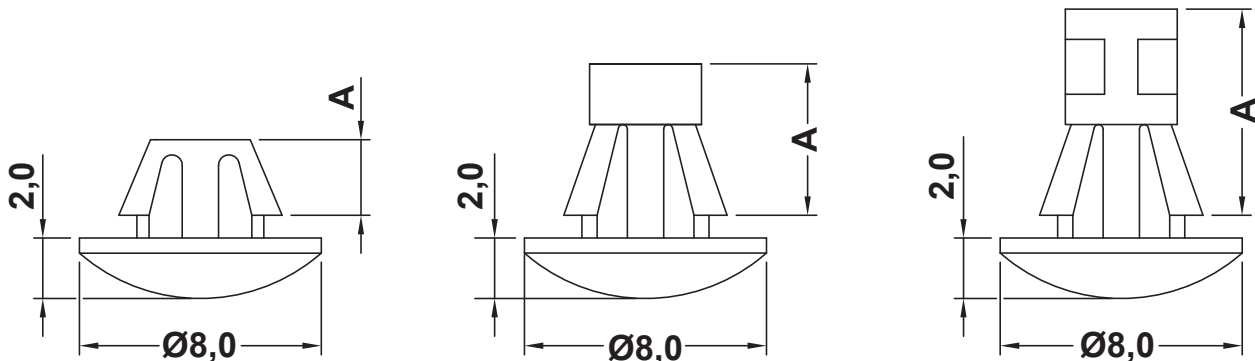

**HOLE IN CHASSIS Ø4,0
CHASSIS THICKNESS 0,8 - 1,6**

PART NO.	A
11400AA0002.5	2.5

PART NO.	A
11400AA0003.2	3.2
11400AA0004.0	4.0
11400AA0004.5	4.5
11400AA0005.0	5.0
11400AA0005.5	5.5

PART NO.	A
11400AA0006.0	6.0
11400AA0006.4	6.4
11400AA0007.0	7.0
11400AA0007.5	7.5
11400AA0008.0	8.0
11400AA0009.0	9.0
11400AA0009.5	9.5
11400AA0010.0	10.0
11400AA0011.1	11.1
11400AA0012.0	12.0
11400AA0012.7	12.7
11400AA0014.0	14.0
11400AA0016.0	16.0

NOTE: MADE OF EQUIVALENT MATERIAL.

				TITLE SPACER SUPPORT	
				MATERIAL PA66 V2 (UL94)	DATE 26/09/2017
				COLOR NATURAL	DRAWN R.F.
PART NUMBER SEE TABLE		DRAWING NUMBER 17.09.26.11400.0.E		CHECK	
SIZE A4	SCALE NTS	UNIT mm	REV C	UNLESS OTHERWISE SPECIFIED TOLERANCE SEE ABOVE	
APPROVED					