

DIM.	TOL.
5mm DOWN	±0.2
5~20mm	±0.3
20~40mm	±0.4
40~60mm	±0.5
60 100mm	±0.8
100mm UP	±1.0

REVISIONS			
REV	DESCRIPTION	DATE	BY

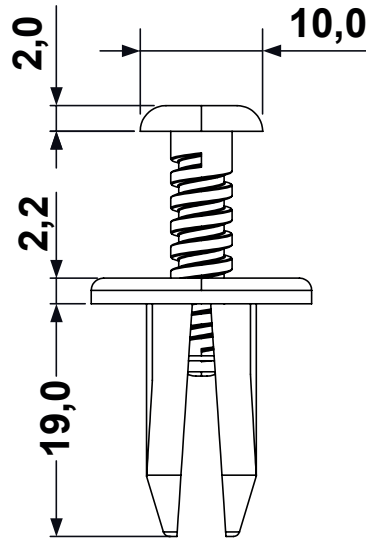

PANEL HOLE Ø 8,0mm
THICKNESS 6,0 - 14,0mm

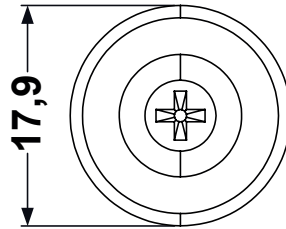

SCRIVETS		TITLE	
		MATERIAL	DATE
		COLOR	DRAWN
PART NUMBER		DRAWING NUMBER	
0962AA01		17.09.25.0962.0.E	
SIZE		UNIT	REV
A4	NTS	mm	C
UNLESS OTHERWISE SPECIFIED TOLERANCE		APPROVED	
SEE ABOVE			

MATERIAL		DATE	
PA66 V2 (UL94)		25/09/2017	
COLOR		DRAWN	
BLACK		R.F.	
PART NUMBER		DRAWING NUMBER	
0962AA01		17.09.25.0962.0.E	
SIZE		UNIT	REV
A4	NTS	mm	C
UNLESS OTHERWISE SPECIFIED TOLERANCE		APPROVED	
SEE ABOVE			