

| DIM.     | TOL. |
|----------|------|
| 5mm DOWN | ±0.2 |
| 5~20mm   | ±0.3 |
| 20~40mm  | ±0.4 |
| 40~60mm  | ±0.5 |
| 60~100mm | ±0.8 |
| 100mm UP | ±1.0 |

| REVISIONS |             |      |    |
|-----------|-------------|------|----|
| REV       | DESCRIPTION | DATE | BY |
|           |             |      |    |
|           |             |      |    |

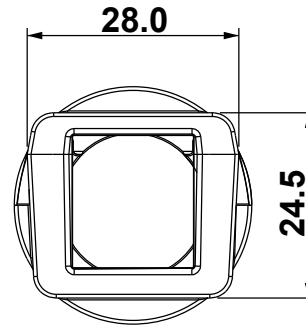

Reccomended cut-out::  
Ø25.5mm

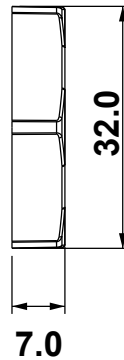
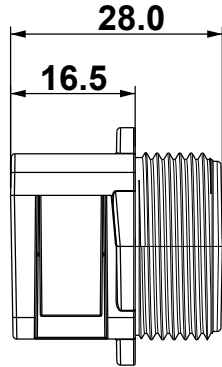
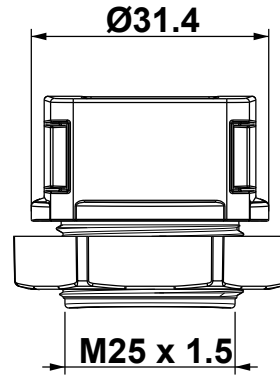
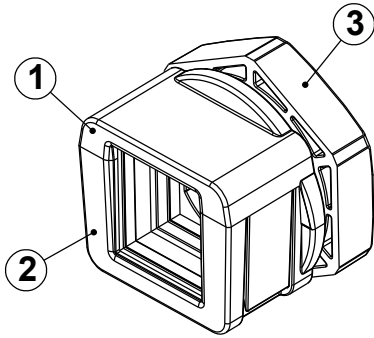
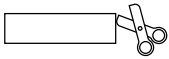

|  |             |                |                   |  |  |  |  |             |
|--|-------------|----------------|-------------------|--|--|--|--|-------------|
|  | <b>IP54</b> | <b>NEMA 12</b> | <b>UL TYPE 12</b> |  |  |  |  | <b>IK10</b> |
|--|-------------|----------------|-------------------|--|--|--|--|-------------|

Temperature: -40°C ... +130°C  
Properties: halogen-free, silicone-free

| Part Number      | Color |
|------------------|-------|
| <b>15941FG01</b> | BLACK |
| <b>15941FG11</b> | GREY  |

Compatible with:

| Id | Description        | Material | Q.ty |
|----|--------------------|----------|------|
| 1  | Top                | PC       | 1    |
| 2  | Bottom             | PC       | 1    |
| 3  | M25 Locknut        | PA       | 1    |
| 4  | Gasket (not shown) | NBR      | 1    |

|      | Single    | Double    | Quadruple |
|------|-----------|-----------|-----------|
|      |           |           |           |
| From | 15913PSxx | 15927PSxx | 15933PSxx |
| To   | 15926PSxx | 15932PSxx | 15938PSxx |

|             |  |                            |  |                                    |  |
|-------------|--|----------------------------|--|------------------------------------|--|
|             |  | TITLE                      |  | <b>SPLITTABLE CABLE GLANDS OSF</b> |  |
|             |  | MATERIAL                   |  | SEE TABLE                          |  |
| PART NUMBER |  | DRAWING NUMBER             |  | DATE                               |  |
| SEE TABLE   |  | 22.01.31.15941.0.E         |  | 31/01/2022                         |  |
| SIZE        |  | SCALE                      |  | DRAWN                              |  |
| A4          |  | 1:1                        |  | A.C.                               |  |
| UNIT        |  | REV                        |  | CHECK                              |  |
| mm.         |  | A                          |  |                                    |  |
| TOLERANCE   |  | UNLESS OTHERWISE SPECIFIED |  | APPROVED                           |  |
| SEE ABOVE   |  | SEE ABOVE                  |  |                                    |  |