

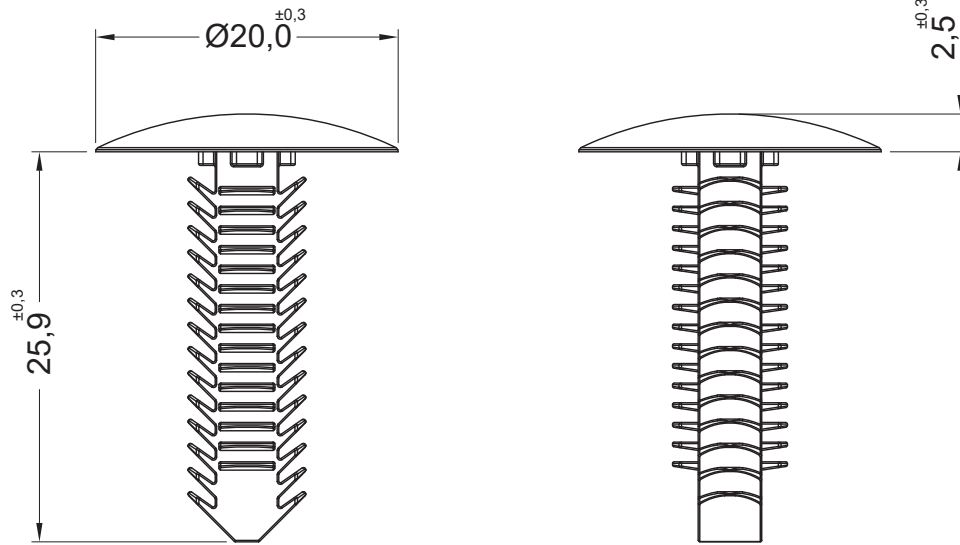

DIM.	TOL.
5mm DOWN	±0.2
5~20mm	±0.3
20~40mm	±0.4
40~60mm	±0.5
60~100mm	±0.8
100mm UP	±1.0

REVISIONS			
REV	DESCRIPTION	DATE	BY



**MOUNTING HOLE: Ø 7,15**  
**PANEL THICKNESS: 1,6 - 22,3**

				TITLE <b>SNAP RIVET</b>	
				MATERIAL PA 66 V2(UL94)	DATE 27/07/2022
PART NUMBER 18219AA01				DRAWN A.C.	
				DRAWING NUMBER 22.07.27.18219.0.E	
SIZE A4				CHECK	
				SCALE 2:1	
UNIT mm.				APPROVED	
				REV A	
UNLESS OTHERWISE SPECIFIED TOLERANCE SEE ABOVE				BLACK	