

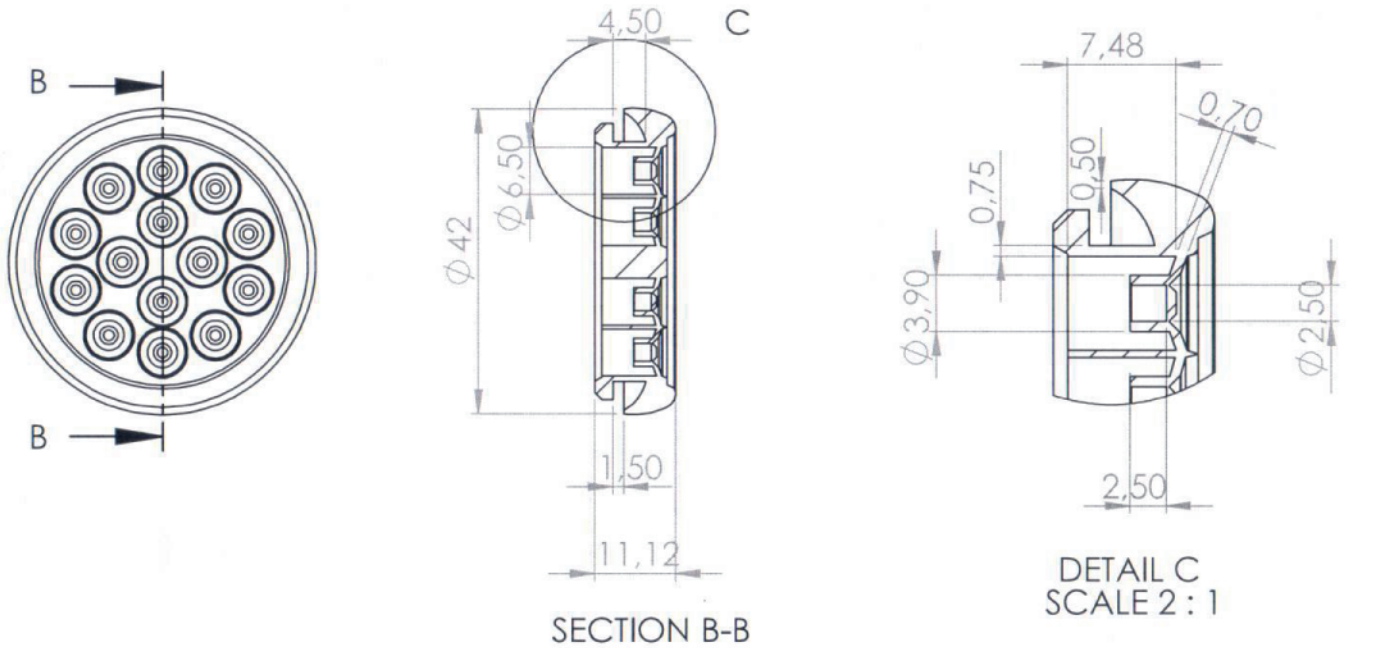

DIM.	TOL.
5mm DOWN	±0.2
5~20mm	±0.3
20~40mm	±0.4
40~60mm	±0.5
60~100mm	±0.8
100mm UP	±1.0

REVISIONS			
REV	DESCRIPTION	DATE	BY

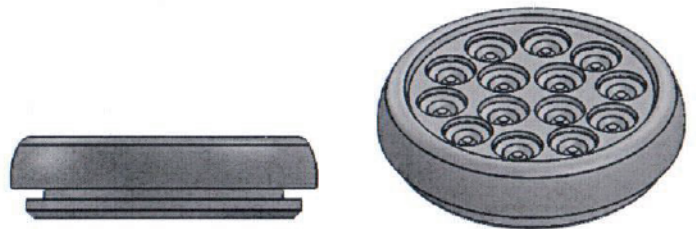

PANEL HOLE: ϕ 32,0
 PANEL THICKNESS: 1,5 - 5,0 mm
 WORKING TEMPERATURE: -40°C.....100°C



				TITLE MULTI-HOLE GROMMET 14 x 3-5,5			
				MATERIAL TPE		DATE 15/09/2015	
				HARDNESS		DRAWN S.P.	
PART NUMBER 22009PF117035		DRAWING NUMBER 15.09.15.2200.0.E		COLOR RAL 7035		CHECK	
SIZE A4	SCALE NTS	UNIT mm	REV A	UNLESS OTHERWISE SPECIFIED TOLERANCE SEE ABOVE		APPROVED	