

DIM.	TOL.
5mm DOWN	±0.2
5~20mm	±0.3
20~40mm	±0.4
40~60mm	±0.5
60~100mm	±0.8
100mm UP	±1.0

REVISIONS			
REV	DESCRIPTION	DATE	BY

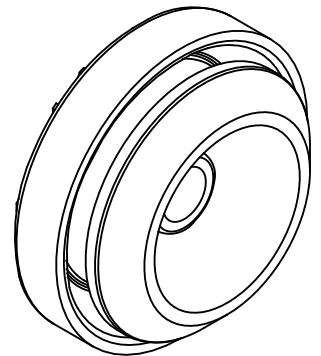
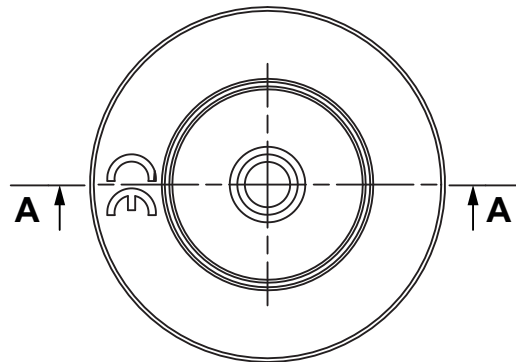
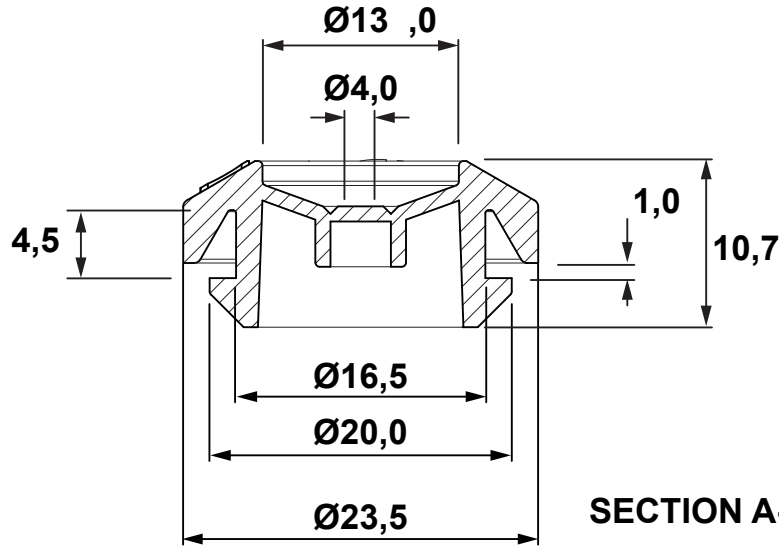

P/N	color	material
22001PF019011	RAL 9011	TPE-SEBS
22001PF117035	RAL 7035	TPE-SEBS
22001PV02	WHITE	TPE-SEBS V0

**MAX. PANEL THICKNESS: MIN. 1,0 ... MAX. 4,5**  
**HOLE PANEL: 16,5**  
**WORKING TEMPERATURE: -40°C ... + 100°C**  
**PROTECTION IP67**



TITLE <b>GROMMET</b>		DATE 04/04/2022	
MATERIAL SEE ABOVE		DRAWN A.C.	
COLOR SEE ABOVE		CHECK	
UNLESS OTHERWISE SPECIFIED TOLERANCE SEE ABOVE		APPROVED	

PART NUMBER SEE ABOVE		DRAWING NUMBER 22.04.04.22001.0.E	
SIZE A4	SCALE 2:1	UNIT mm.	REV A