

Dimensions	Tolerance
L≤10	±0.2
10<L≤30	±0.3
30<L≤50	±0.5
50<L≤100	±0.7
100<L≤250	±1.2
ABOVE 250	±1.5

REVISIONS			
REV	DESCRIPTION	DATE	BY

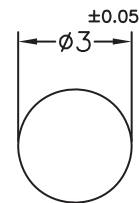
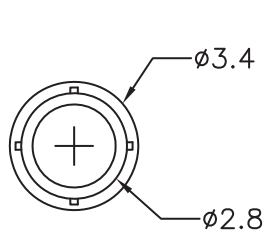
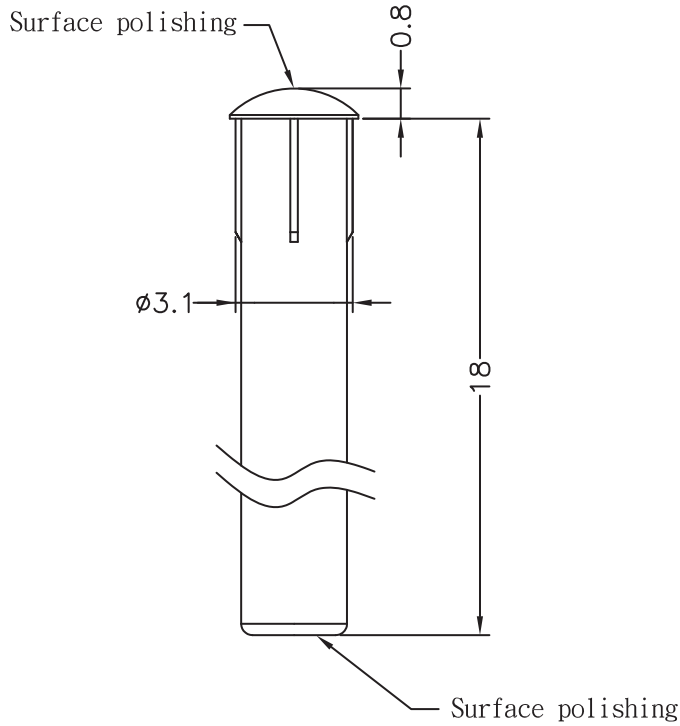

MOUNTING HOLE

NOTE:

1. Measurement does not include gate which raises under 0.3 mm

				TITLE LIGHT PIPE		
				MATERIAL PC UL94V-2	DATE 16/09/2016	
				DRAWN R.F.		
PART NUMBER 10614NA00		DRAWING NUMBER 16.09.16.10614.0.E		COLOR CLEAR		CHECK
SIZE A4	SCALE NTS	UNIT mm	REV A	UNLESS OTHERWISE SPECIFIED TOLERANCE SEE ABOVE		APPROVED