

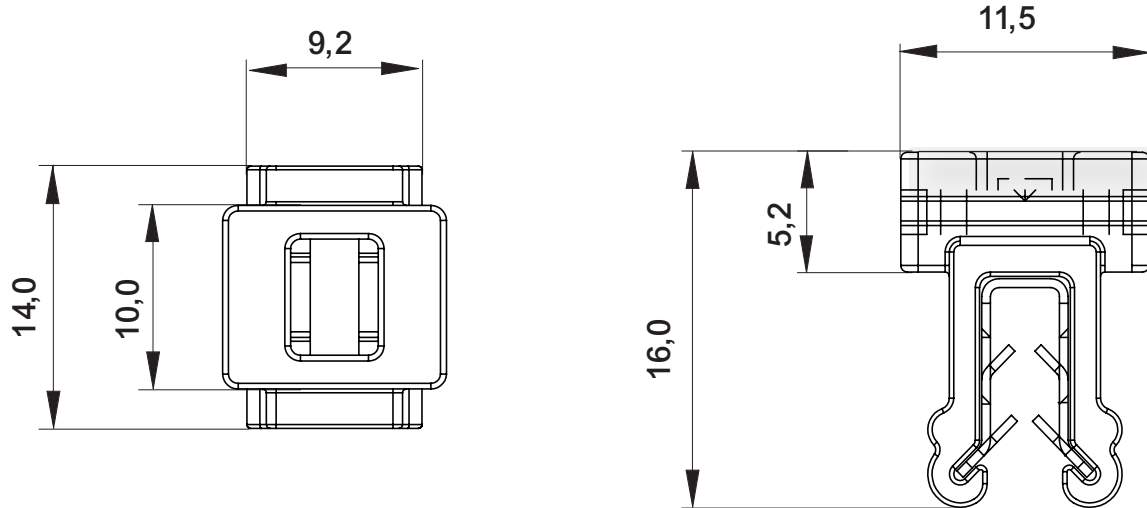

DIM.	TOL.
5mm DOWN	±0.2
5~20mm	±0.3
20~40mm	±0.4
40~60mm	±0.5
60~100mm	±0.8
100mm UP	±1.0

REVISIONS			
REV	DESCRIPTION	DATE	BY



**MATERIAL:**  
**CLIP: PA 6.6**  
**TEETH CLIP: IRON**  
**WORKING TEMPERATURE: -35°C ~ +85°C**

		TITLE <b>EDGE CLIP</b>	
		MATERIAL SEE ABOVE	DATE 24/01/2024
PART NUMBER 17935AA01GS		DRAWING NUMBER 24/01/24.17935.0.E	
DRAWN E.B		COLOR BLACK	CHECK
SIZE A4	SCALE NTS	UNIT mm.	REV A
UNLESS OTHERWISE SPECIFIED TOLERANCE SEE ABOVE		APPROVED	