

DIM.	TOL.
5mm DOWN	±0.2
5~20mm	±0.3
20~40mm	±0.4
40~60mm	±0.5
60~100mm	±0.8
100mm UP	±1.0

REVISIONS			
REV	DESCRIPTION	DATE	BY

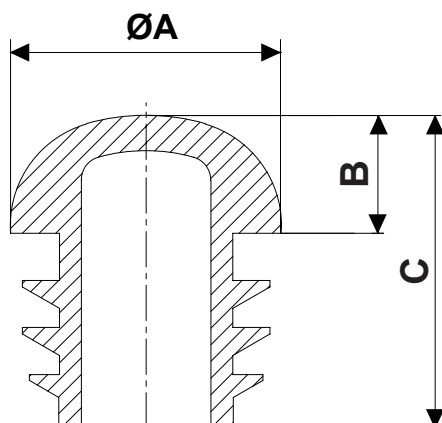
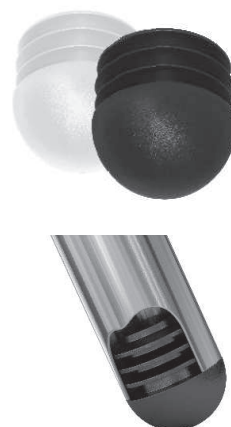

P/N	A	B	C	Ø HOLE
3428EA01	18,0	7,5	20,0	15,0
3429EA01	20,0	9,0	24,5	17,0
3430EA01	22,0	10,0	25,0	19,0
3431EA01	25,0	11,0	26,0	22,0
3432EA01	30,0	13,5	32,0	27,0
3433EA01	32,0	16,5	35,5	29,0
3434EA01	35,0	17,0	37,0	32,0

				TITLE ROUND PLUGS	
				MATERIAL PE-LD	
PART NUMBER SEE TABLE				DRAWING NUMBER 21.04.12.34XX.0.E	
				COLOR BLACK	
SIZE A4		SCALE NTS		UNIT mm.	
REV A		UNLESS OTHERWISE SPECIFIED TOLERANCE SEE ABOVE		APPROVED	