

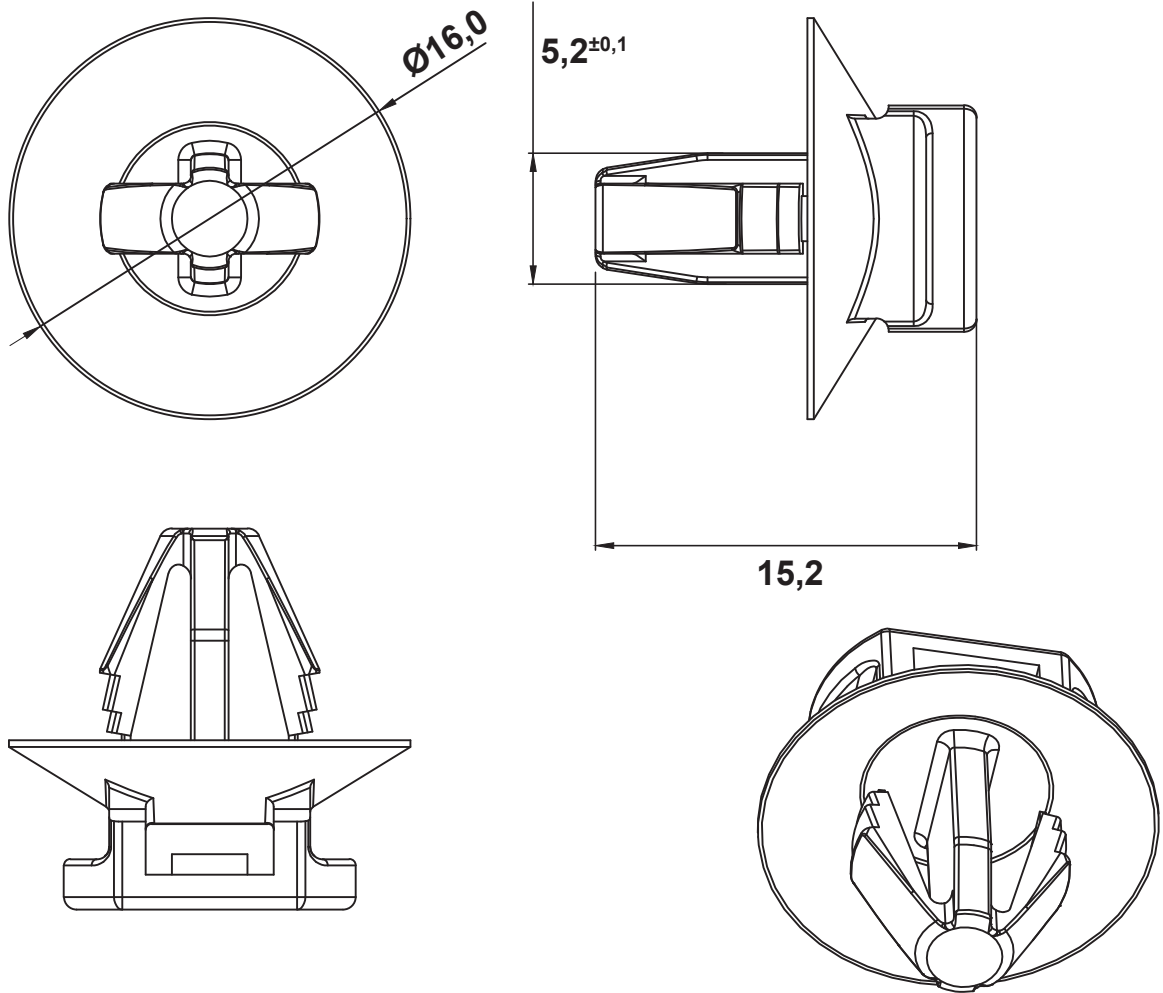

DIM.	TOL.
5mm DOWN	±0.2
5~20mm	±0.3
20~40mm	±0.4
40~60mm	±0.5
60~100mm	±0.8
100mm UP	±1.0

REVISIONS			
REV	DESCRIPTION	DATE	BY



**MOUNTING HOLE: Ø5,5-Ø6,0**  
**THICKNESS: 0,6-3,0**  
**INSERTION FORCE ≤60N, EXTRACTION FORCE ≥150N.**  
**WORKING TEMPERATURE: -35°C...+100°C**

		TITLE <b>PUSH MOUNT CABLE TIE</b>	
		MATERIAL PA 6.6	DATE 18/07/2025
PART NUMBER 19719AA01		DRAWING NUMBER 25/07/18.19719.E	
COLOR BLACK		DRAWN A.C.	
SIZE A4	SCALE NTS	UNIT mm.	REV A
UNLESS OTHERWISE SPECIFIED TOLERANCE SEE ABOVE		CHECK APPROVED	