

DIM.	TOL.
5mm DOWN	±0.2
5~20mm	±0.3
20~40mm	±0.4
40~60mm	±0.5
60~100mm	±0.8
100mm UP	±1.0

REVISIONS			
REV	DESCRIPTION	DATE	BY

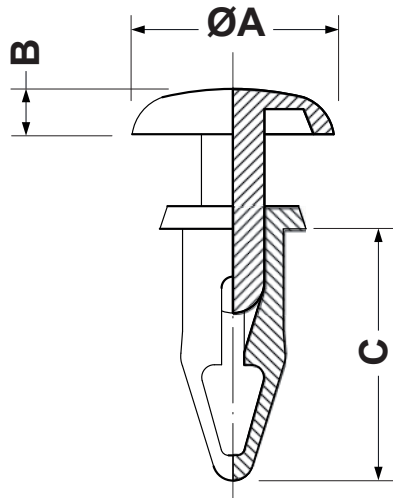

P/N	A	B	C	HOLE	THICKNESS
9825AA01	6,4	1,6	9,8	Ø 3,6	2,0 - 3,5
9826AA01	6,4	1,6	11,4	Ø 3,6	3,5 - 5,0
9827AA01	6,4	1,6	13,6	Ø 3,6	5,0 - 6,5
9828AA01	8,0	1,8	10,0	Ø 4,1	2,0 - 3,5
9829AA01	8,0	1,8	12,0	Ø 4,1	3,5 - 5,5
9830AA01	8,0	1,8	14,0	Ø 4,1	5,5 - 7,5
9831AA01	9,0	2,2	11,4	Ø 4,9	2,0 - 3,5
9832AA01	9,0	2,2	13,2	Ø 4,9	3,5 - 5,5
9833AA01	9,0	2,2	15,2	Ø 4,9	5,5 - 7,5

NOTES:

OPERATING TEMPERATURE: -35°C ~ +85°C

		TITLE SNAP RIVET	
		MATERIAL PA 66 V2 (UL94)	DATE 30/07/2021
PART NUMBER SEE TABLE		DRAWING NUMBER 21.07.30.98XX.0.E	
DRAWN R.F.		COLOR BLACK	CHECK
SIZE A4	SCALE NTS	UNIT mm.	REV A
UNLESS OTHERWISE SPECIFIED TOLERANCE SEE ABOVE		APPROVED	