

DIM.	TOL.
5mm DOWN	±0.2
5~20mm	±0.3
20~40mm	±0.4
40~60mm	±0.5
60~100mm	±0.8
100mm UP	±1.0

REVISIONS			
REV	DESCRIPTION	DATE	BY

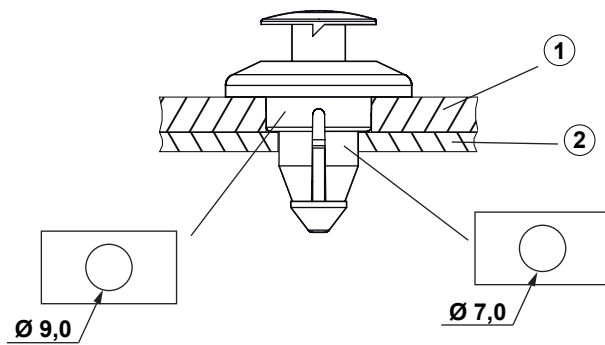
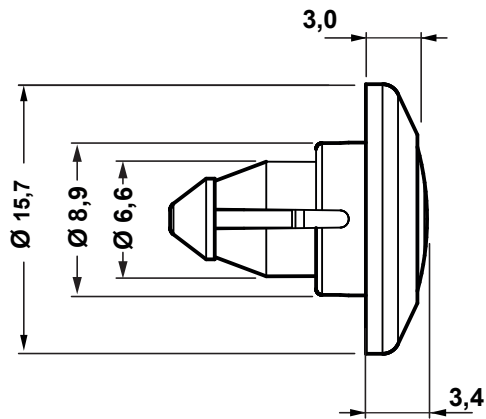
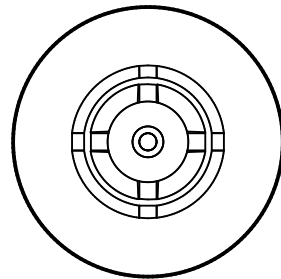
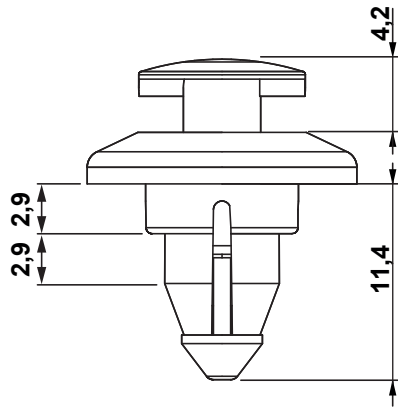

**PANEL 1:**  
Hole: Ø 9,0  
Thickness: ≥ 3mm

**PANEL 2:**  
Hole: Ø 7,0  
Thickness: ≤ 5,2mm - thickness 1

				TITLE <b>QUARTER TURN RIVET</b>	
				MATERIAL POM HB(UL94)	
PART NUMBER 19514GA01				DRAWN A.C.	
DRAWING NUMBER 25.05.05.19514.0.E				CHECK	
COLOR BLACK				APPROVED	
SIZE A4	SCALE NTS	UNIT mm.	REV A	UNLESS OTHERWISE SPECIFIED TOLERANCE SEE ABOVE	