

DIM.	TOL.
5mm DOWN	±0.2
5~20mm	±0.3
20~40mm	±0.4
40~60mm	±0.5
60~100mm	±0.8
100mm UP	±1.0

REVISIONS			
REV	DESCRIPTION	DATE	BY

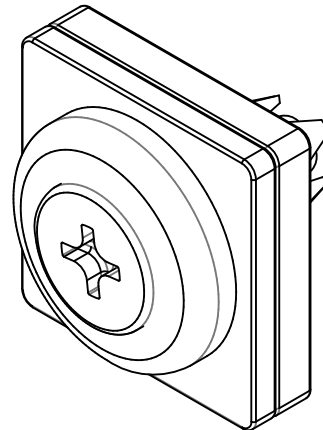
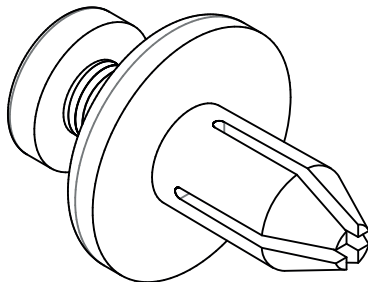
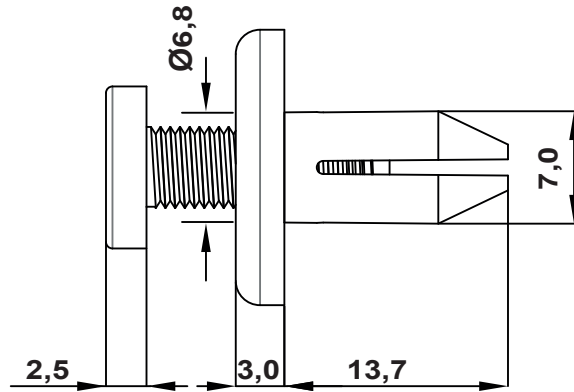
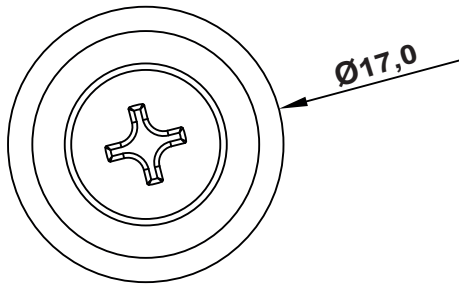

MOUNTING HOLE: Ø7,0
PANEL THICKNESS: 4,0-5,5
HEAD HEIGHT: 3,0 + 1,3

		TITLE SCREW RIVET	
		MATERIAL PA 6.6 V2(UL94)	DATE 06/05/2025
PART NUMBER 19518AA01		DRAWN A.C.	
DRAWING NUMBER 25/05/05.X.X.E		CHECK	
SIZE A4	SCALE NTS	COLOR BLACK	APPROVED
UNIT mm.	REV A	UNLESS OTHERWISE SPECIFIED TOLERANCE SEE ABOVE	