

DIM.	TOL.
5mm DOWN	±0.2
5~20mm	±0.3
20~40mm	±0.4
40~60mm	±0.5
60~100mm	±0.8
100mm UP	±1.0

REVISIONS			
REV	DESCRIPTION	DATE	BY

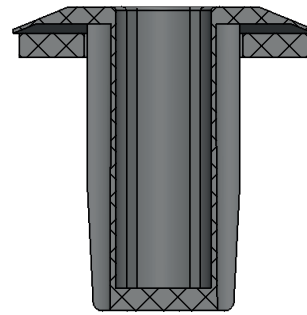
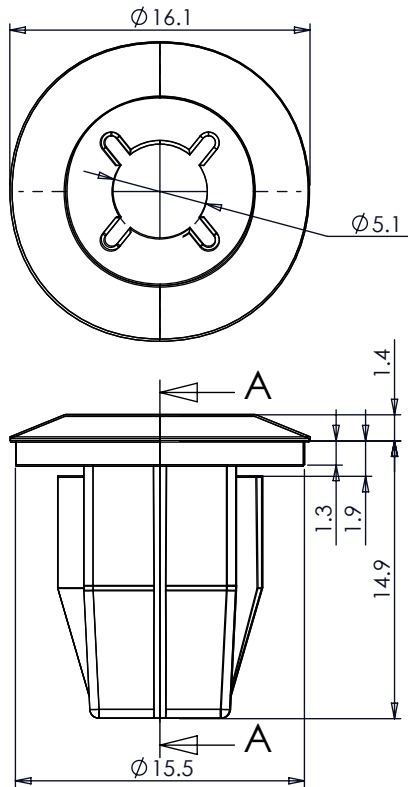

SECTION A-A

MATERIAL:

BODY: POM HB(UL94)

GASKET: NBR

MOUNTING HOLE: 8,5 x 8,5

PANEL THICKNESS: 0,7 - 1,2

SCREW HOLE SIZE: Ø5,1

				TITLE SEALED SCREW GROMMET	
				MATERIAL SEE ABOVE	
PART NUMBER 19582GA00				DRAWING NUMBER 25.04.18.19582.E	
				COLOR NATURAL	
SIZE A4	SCALE NTS	UNIT mm.	REV A	UNLESS OTHERWISE SPECIFIED TOLERANCE SEE ABOVE	
				CHECK APPROVED	