

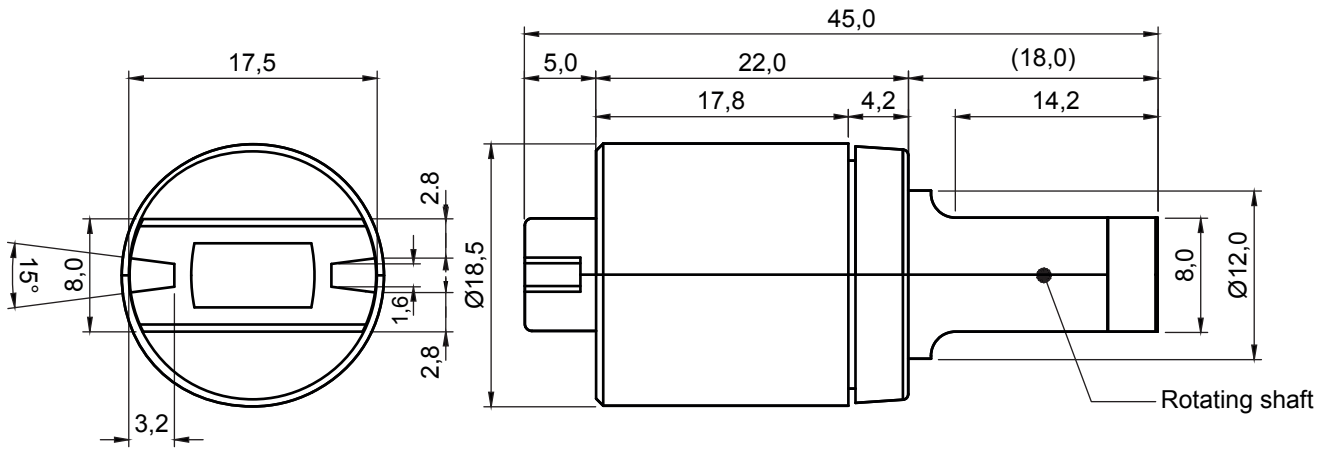

DIM.	TOL.
5mm DOWN	±0.2
5~20mm	±0.3
20~40mm	±0.4
40~60mm	±0.5
60~100mm	±0.8
100mm UP	±1.0

REVISIONS			
REV	DESCRIPTION	DATE	BY



P/N	ROTATION	TORQUE	RETURN TORQUE	COLOUR
19650XX01	RIGHT DIRECTION	1 N-m (10kgf-cm)	0.3N-m (3kgf-cm)	BLACK
19651XX01	LEFT DIRECTION	1 N-m (10kgf-cm)	0.3N-m (3kgf-cm)	BLACK WITH GREY ROTATING SHAFT
19652XX01	RIGHT DIRECTION	1.5 N-m (15kgf-cm)	0.5N-m (5kgf-cm)	BLACK
19653XX01	LEFT DIRECTION	1.5 N-m (15kgf-cm)	0.5N-m (5kgf-cm)	BLACK WITH GREY ROTATING SHAFT
19654XX01	RIGHT DIRECTION	1.8 N-m (18kgf-cm)	0.8N-m (8kgf-cm)	BLACK
19655XX01	LEFT DIRECTION	1.8 N-m (18kgf-cm)	0.8N-m (8kgf-cm)	BLACK WITH GREY ROTATING SHAFT

MAX. ANGLE 115°
WORKING TEMPERATURE: -5 C° ~ +50°C
OIL TYPE: SILICONE OIL

				TITLE BARREL DAMPER	
				MATERIAL PBT	DATE 23/04/2025
PART NUMBER SEE TABLE				DRAWN E.B.	
				CHECK	
DRAWING NUMBER 25.04.23.196X.0.E				COLOR SEE TABLE	
SIZE A4	SCALE NTS	UNIT mm.	REV A	UNLESS OTHERWISE SPECIFIED TOLERANCE SEE ABOVE	
				APPROVED	