

DIM.	TOL.
5mm DOWN	±0.2
5~20mm	±0.3
20~40mm	±0.4
40~60mm	±0.5
60~100mm	±0.8
100mm UP	±1.0

REVISIONS			
REV	DESCRIPTION	DATE	BY

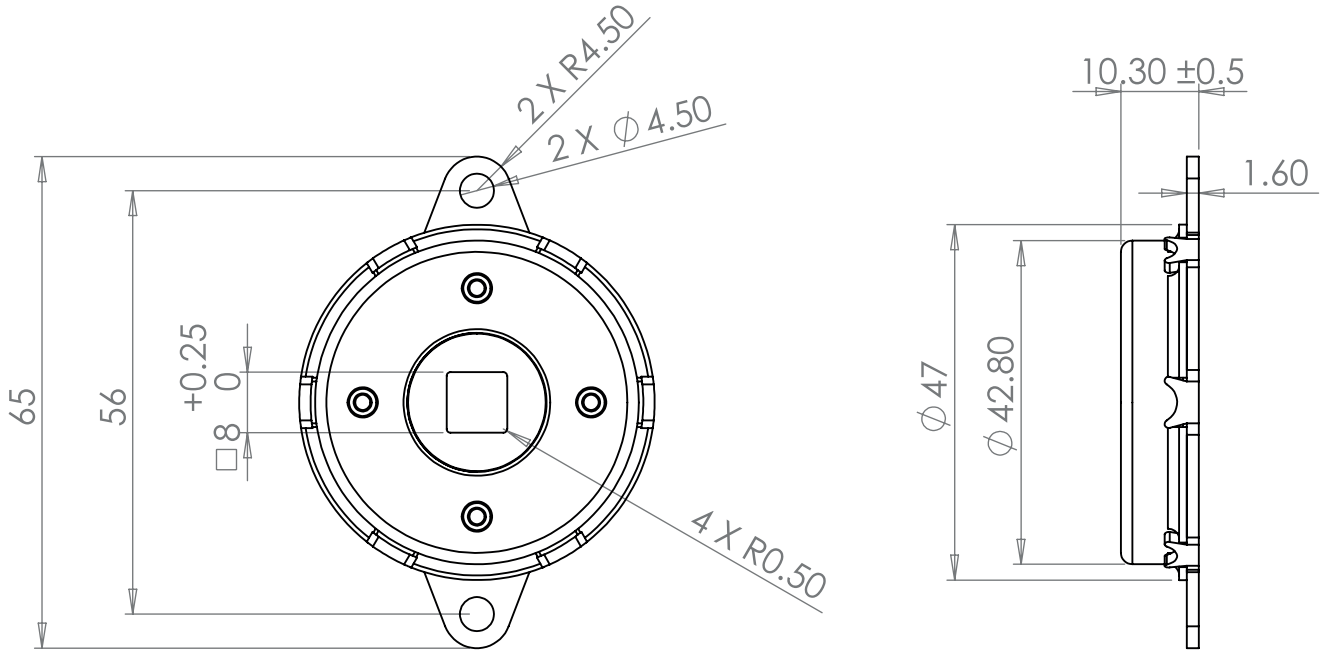

RECOMMENDED SHAFT DIMENSIONS

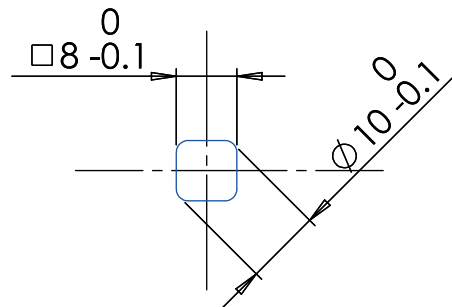

RATED TORQUE: 1.6 ± 0.3Nm (16 ± 3kgf.cm)
DAMPING DIRECTION: BOTH DIRECTIONS
MAX. ROTATION SPEED: 50 RPM
MAX. CYCLE RATE: 12 CYCLE/MIN
WORKING TEMPERATURE: -10 ~ +50°C

				TITLE HI TORQUE ROTARY DAMPER-BOTH DIRECTIONS	
				MATERIAL STEEL / GLASS FILLED NYLON / SILICONE	DATE 23/04/2025
PART NUMBER 19663XX94		DRAWING NUMBER 25.04.23.19663.0.E		COLOR	CHECK
SIZE A4	SCALE NTS	UNIT mm.	REV A	UNLESS OTHERWISE SPECIFIED TOLERANCE SEE ABOVE	APPROVED
				DRAWN E.B.	